



PSCU/2 Control Unit Installation Instructions

INTRODUCTION

PSCU/2 control units are designed to be used with Tapeswitch pressure sensitive sensors, such as ribbon switches, sensing edges, bumpers, and presence sensing switching mats, in control or low risk safety applications. For control applications, either two wire (i.e. single lead) sensors or four wire (i.e. fail-safe lead) sensors can be used. For low risk safety applications, only sensors with fail-safe wiring should be used.

PRODUCT DESCRIPTION

The unit operates from a 24 Vdc supply and provides internal current limiting. This supply operates the sensor and control circuitry. The unit is housed in an 11-pin enclosure. A mating 11-pin socket is required for mounting. This unit is intended to be mounted in an existing electrical enclosure on the machine. This existing enclosure must be sealed to a minimum rating of IP54. See figure 1 for unit dimensions.

This unit can be used to monitor a sensor (or several sensors connected in series). Refer to attached diagrams. The sensor is effectively a normally open switch. When the sensor is actuated, i.e. pressure is applied to it, the switch closes causing the output relay to de-energize and therefore the output contacts to change state. The output is a set of volt-free changeover relay contacts.

The unit provides a manual or auto reset function. In manual reset mode, the reset function provides start and restart interlock functions as follows:

Start Interlock - When power is applied to the system, the output relay energized until the reset signal has been applied.

Restart Interlock - Once the sensor has been actuated and the output relay has been de-energized, it cannot be re-energized until the reset signal has been applied.

In auto reset mode, the output relay will be energized whenever power is applied to the system and the sensor is clear.

In manual or auto reset, the output relay will not energize while the sensor is actuated. If a short circuit or open circuit fault occurs in a four wire sensor, the output relay will not energize.

INSTALLATION (see figure 2)

Power Supply - Connect +24 Vdc to terminal 2, and 0 V to terminal 10 as shown in Figure 2. Maximum power consumption is 6 VA.

Sensor Connection - For two-wire sensors, connect one sensor wire to terminal 5, connect the other sensor wire to terminal 7, jumper terminal 5 to terminal 3, and jumper terminal 7 to terminal 4. For four-wire sensors see Figure 2 and Table 1 for sensor connections.

Reset Connection - For manual reset, connect a momentary, normally-open switch across terminals 8 and 9. For auto reset, connect a jumper across terminals 8 and 9.

Output Connection - Connect the output contacts into the machine control system to provide required function, terminals 1, 6, and 11.

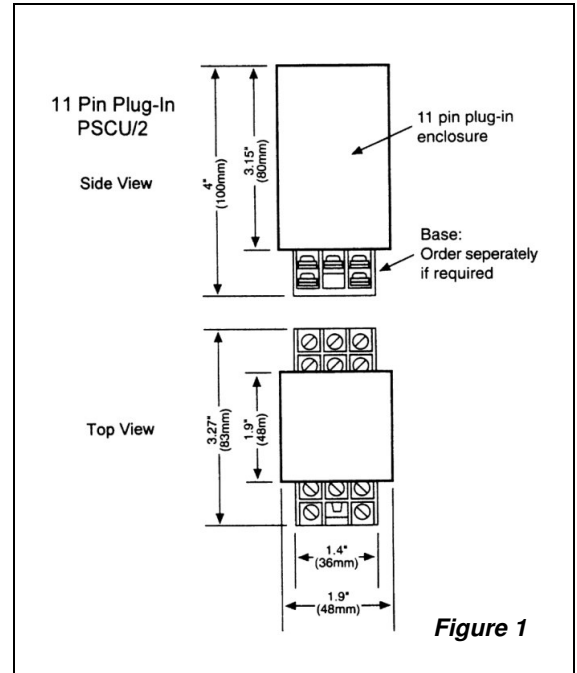
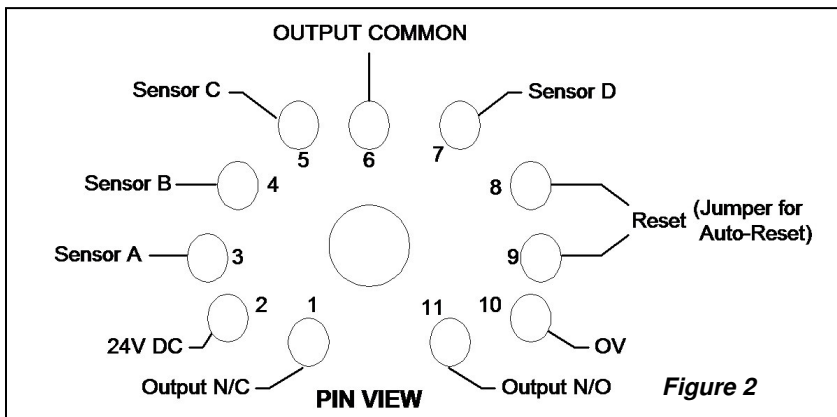

Table 1

SENSOR TYPE	SENSOR CONNECTION			
	A	B	C	D
CKP and Armormats	Black	Red	Yellow	White
Mats, Edges and Ribbon Switch	Black 1	White 1	Black 2	White 2
Any Edge or Ribbon Switch	Ribbed 1	Smooth 1	Ribbed 2	Smooth 2
Terminal Numbers PSCU/2	3	4	5	7

Table 2

Supply Voltage	24V DC
Power Consumption	6 VA
Temperature Range: Operating Storage	0 to 50 degrees C -20 to 70 degrees C
Reset Function	Manual or Auto (jumper selectable)
Outputs: Type Rating	Changeover relay contacts 4A @ 240V AC 50/60 Hz



INTERCONNECT DIAGRAMS, DAISY CHAINED/SERIES CONNECTION

Multiple Mats with 4 Conductor Standard Color Coded Lead Wire

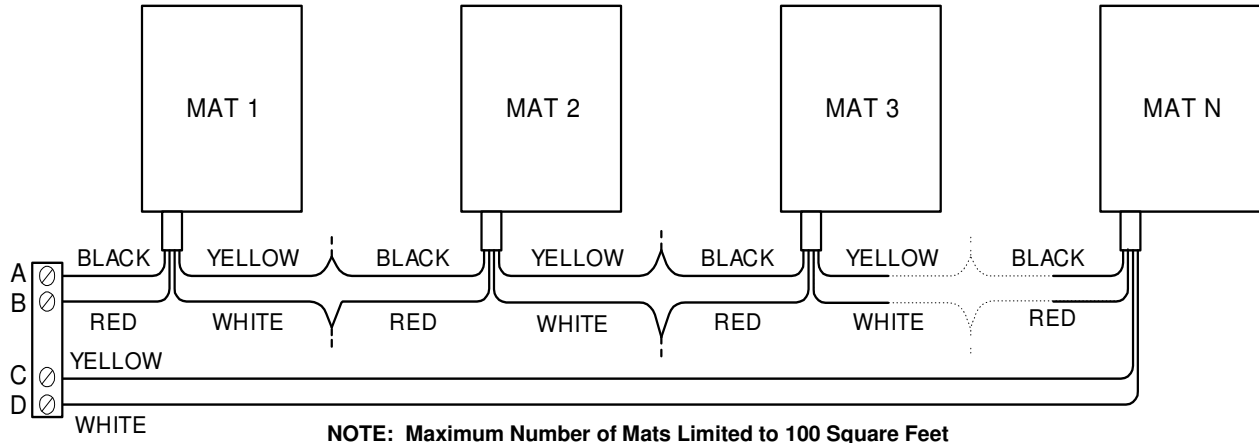

Multiple Mats with Optional 2 Conductor Standard Color Coded Lead Wire

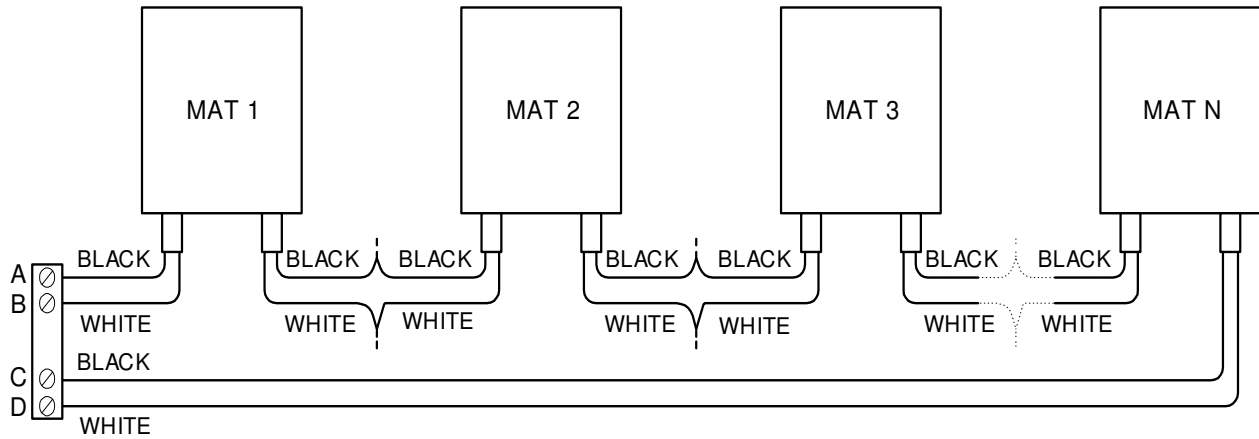

Multiple Sensing Edges, Bumpers and Ribbon Switches with Color Coded Wire

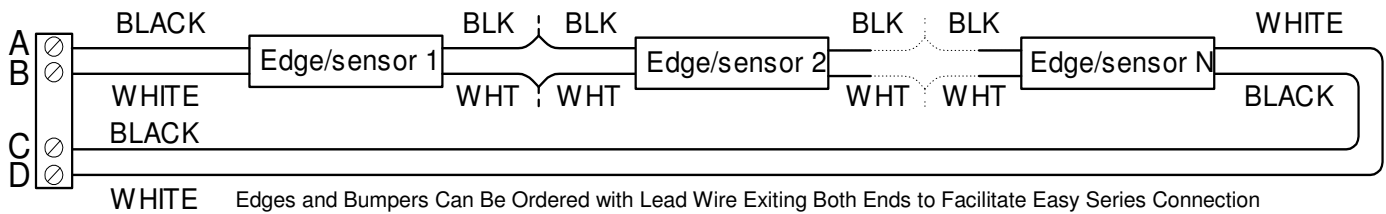

NOTE: Maximum Number of Edges, Bumpers, and Ribbon Switches Limited to 200 Feet

Multiple Sensing Edges, Bumpers and Ribbon Switches with Non-Color Coded Zip Cord Wire

