



BC-4 Blanking Interface Controller Instruction Manual

WARNING

Tapeswitch photo-electric safety systems are intended to protect operators working at or near dangerous machinery. They can only perform this function if they are correctly fitted to a suitable machine. It is essential that the full contents of this manual and all the authoritative documents referred to herein are fully understood before any attempt at installation is made. If in doubt contact Tapeswitch Corporation.

IMPORTANT

This manual must accompany the product throughout its working life. Those persons responsible for the product must ensure that all persons involved in the installation, commissioning, operation, maintenance and servicing of the product have access to all the information supplied by the manufacturers of the machine and its safety system.

Installation of the BC-4 Blanking Interface Controller is to be performed in conjunction with the B-Series Technical Manual, see 4.0 Interface and Auxiliary Units Sections.

When power is first applied to the light curtain system via the BC-4, insure that the program key switch is in the “OFF” position.

Note: This Manual must be used with B-Series Light Curtains with serial Number ending in D02 and above.

CONTENTS

1.	INTRODUCTION	
1.1	GENERAL	4
1.2	TYPES OF BLANKING	5
1.2.1	<i>General</i>	5
1.2.2	<i>Fixed Blanking</i>	5
1.2.3	<i>Floating Blanking</i>	5
1.2.4	<i>Fixed and Floating Blanking in Combination</i>	6
1.3	IMPLICATIONS OF BLANKING	6
1.3.1	<i>Effect of Blanking on Detection Capability</i>	6
1.3.2	<i>Effect of Blanking on Separation Distance</i>	7
1.3.3	<i>Calculation of Effective Detection Capability</i>	8
2.	BC-1 PROGRAMMING UNIT	
2.1	UNIT DESCRIPTION	9
2.2	PROGRAMMING INSTRUCTIONS	10
2.3	OPERATING CONSIDERATIONS	11
2.3.1	<i>BC-4 Operation</i>	11
2.3.2	<i>Curtain Operation</i>	11
3.	MANAGEMENT ISSUES	
3.1	BLANKING TEST PROCEDURE	11
3.2	DETECTION CAPABILITY - TEST & INDICATION	11
4.	INTERFACE AND AUXILIARY UNITS	
4.1	GENERAL	12
4.1.1	<i>Methods of Interfacing</i>	12
4.2	BC-4 INTERFACE UNIT	13
4.2.1	<i>General Description</i>	13
4.2.2	<i>Operational Sequence and LED Status Description</i>	13
4.2.3	<i>Mechanical</i>	14
4.2.4	<i>Electrical Connections</i>	14
4.2.5	<i>Fuses</i>	16
4.2.6	<i>Test Input</i>	17
4.2.7	<i>Monitor/Auxiliary Output</i>	17

1. INTRODUCTION

The decision process within the light curtain logic is

a relatively simple one, as shown in Figure 2.

1.1 GENERAL

WARNING

Incorrect use of blanking and/or failure to correctly address the implications of using blanking on the management of a machine is potentially very dangerous. It is therefore vital that the requirements for the use of blanking specified in this manual be fully understood and complied with.

The BC-4 Blanking Interface Controller has provisions for programming blanking function on a Tapeswitch light curtain. This includes the B-Series light curtain product line.

Blanking is sometimes confused with other light-curtain-related functions, for example muting, and therefore, it helps to start with an explanation of exactly what blanking is.

First consider the normal operation of a light curtain without blanking. A light curtain typically consists of a grid of parallel beams of infra-red light, each beam consisting of an emitter device at one end and a receiver device at the other (see Figure 1).

If any single beam is obscured, the light curtain will generate a stop signal.

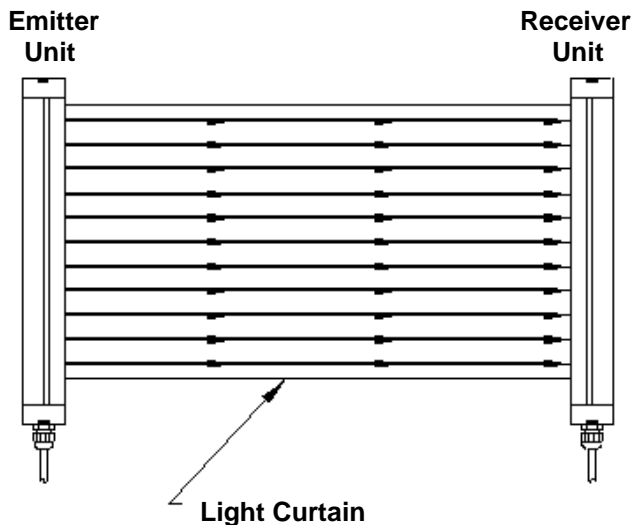

Figure 1

Figure 2

Now consider the operation of a light curtain that is using blanking. With blanking, the unit is able to:

- determine the state of each individual beam
- compare this information with previously programmed requirements
- based on this comparison, decide whether to send a stop signal to the machine.

The light curtain decision process is now a more complex one as shown in Figure 3.

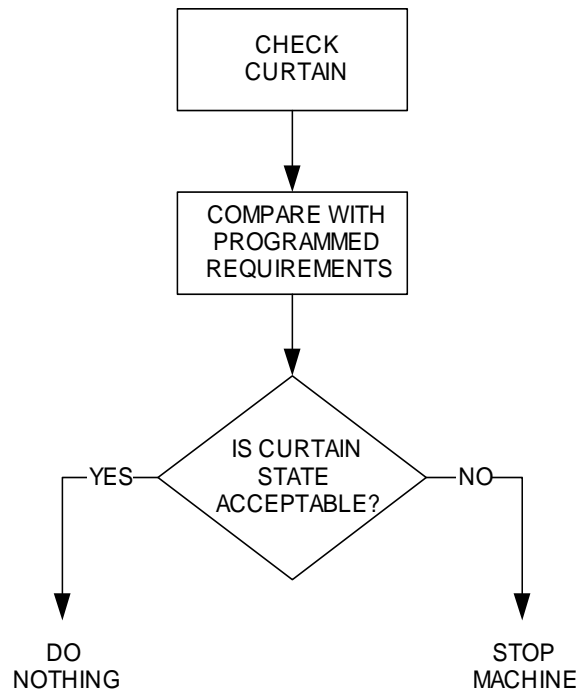

Figure 3

Blanking therefore modifies the basic instinct of the light curtain to stop the machine when any beam is obscured, and makes its response conditional.

Safe use of this modified behavior obviously makes special demands on the design of the light curtain, but equally important are the demands made on the installation, programming, operation and maintenance of the machine/light curtain combination.

Notice that the light curtain can only consider the question:

'Has this state of the curtain been programmed as acceptable?'

It cannot consider the question:

'Is this a safe state for the curtain to be in?'

This is the responsibility of those involved in the use of the machine, and can only be achieved with very careful consideration of all implications of the use of blanking as described in this manual and careful analysis of the application.

1.2 TYPES OF BLANKING

1.2.1 GENERAL

There are basically two types of blanking: fixed and floating. The two types can be used independently or in combination. The operation, purpose and implications of independent and combined use are considered below.

1.2.2 FIXED BLANKING

In fixed blanking, one or more selected beams, at particular positions in the curtain, are allowed to be obscured without a stop signal being generated.

NOTE: The behavior of a fixed blanked beam can be further modified by the use of fixed and floating blanking in combination. This is explained in section 1.2.4.

Fixed blanking is used where correct positioning of the light curtain dictates that some necessary fixtures on a machine, for example sheet supports on a press brake, will obscure some beams during normal operation.

These beams can be selected for fixed blanking so that the presence of the fixture does not cause the curtain to send a stop signal and the machine can be used normally. The curtain ignores the obstruction.

In the B-Series light curtain, once a beam has been specified as 'fixed blanked' it is monitored in 'opposite mode'. If a fixed blanked beam becomes unobscured, the light curtain will generate a stop signal, just as if a normal, non-blanked beam had been obscured.

The B-Series light curtain has positive blanking, which means, once the light curtain is programmed to expect an obstruction, it will ignore this obstruction. However, the light curtain will constantly verify this obstruction is present. If the obstruction is removed, the light curtain views this as a contradiction to how it has been programmed and it will issue a stop signal.

If a fixed blanked beam is not monitored in this way, removal of the fixture would leave an unprotected area in the curtain.

In the B-Series system the programming of fixed blanked beams is achieved by means of a learning function.

Using the BPU4, the light curtain is instructed to learn the state of the curtain, i.e., which beams are clear and which are obscured. This state is recorded in non-volatile memory. For this reason, fixed blanking is also referred to as learned blanking later in this manual.

After programming, the current state of the curtain is continually compared with the recorded state and any deviations will result in a stop signal being generated.

1.2.3 FLOATING BLANKING

Floating blanking allows a number of beams, usually one or two, to be obscured without a stop signal being generated. The term floating blanking is used because an obstruction can move or 'float' within the detection zone without a stop signal being generated, providing that the obstruction does not obscure more than the specified number of beams.

Floating blanking is used to allow an obstruction to move within the detection zone, for example where flexible cables or pipes pass through the detection zone and can move while the machine is operating.

The B-Series light curtain can be programmed for 1-beam floating blanking or 2-beam floating blanking.

The maximum size of an object which will be ignored by the curtain, at any range, is given in Table 1.

Basic Detection Capability	Type of Floating Blanking Used		
	None	1 Beam	2 Beam
14mm	2mm	8mm	17mm
30mm	5mm	15mm	32mm
70mm	5mm	38mm	88mm

Table 1 - Ignored Object Diameter

1.2.4 FIXED AND FLOATING BLANKING IN COMBINATION

When fixed and floating blanking are used in combination, the floating blanking modifies the fixed blanking. Recall that floating blanking, used independently, allows a number of beams to be blocked without generating a stop signal. It allows a number of beams which would normally need to be clear to be obscured. In other words, it allows a number of curtain discrepancies.

This is how floating blanking works with fixed blanking. When a light curtain has been programmed for fixed blanking, some beams need to be clear and all other beams need to be obscured, otherwise a stop signal will be generated. The floating blanking allows a number of curtain discrepancies. So, beams which would normally need to be clear can be obscured, and beams which would normally need to be obscured can be clear.

In the case of the B-Series light curtain, the maximum number of allowed curtain discrepancies can be set at 1 or 2.

This would allow a fixed blanked object, for example feedstock, to move slightly during machine operation. The maximum allowable movement of a fixed blanked object is given in Table 2.

Basic Detection Capability	Maximum Allowed Object Movement
14mm	9mm
30mm	17mm
70mm	50mm

Table 2

1.3 IMPLICATIONS OF BLANKING

1.3.1 EFFECT OF BLANKING ON DETECTION CAPABILITY

WARNING

Beam blanking changes the detection characteristics of the light curtain and should be used with caution. When blanking is used, always ensure that the safety distance is still sufficient with the modified detection capability.

Blanking of any kind increases the detection capability of a light curtain. The detection capability of a light curtain is the smallest diameter of opaque object which the system can reliably detect.

NOTE: An increase in detection capability is not an improvement. It means that the curtain is less sensitive to intrusions.

The **effective detection capability**, D_e , of the light curtain which is blanked can be calculated using the following formula:

Formula 1: $D_e = D_b + I(N_{fx} + N_{ft})$

where:

- I = beam increment (see Table 3)
- N_{fx} = number of beams in largest contiguous block of fixed blanked beams
- N_{ft} = number of floating blanked beams

Basic Detection Capability	Increment, I
14mm	9mm
30mm	17mm
70mm	50mm

Table 3

Note: Read sections 1.3.2 and 1.3.3 for guidance before using this formula.

1.3.2 EFFECT OF BLANKING ON SEPARATION DISTANCE

As previously explained, the use of any type of blanking increases the detection capability of the light curtain. Detection capability is one of a number of factors used to calculate the separation distance, i.e., the distance at which the light curtain is positioned from the dangerous parts of the machine. (See the light curtain manual for further details).

Normally the greater the detection capability the greater the separation distance, all other factors being equal. Certainly, the use of floating blanking always requires an increase in separation distance.

However, when using fixed blanking, although fixed blanking always increases the detection capability of the light curtain, it is not always necessary to increase the separation distance. This depends entirely on the nature of the obstruction.

Figures 4 and 5 show two obstruction possibilities: complete obstruction and incomplete obstruction.

In the case of incomplete obstruction it is possible for a person to gain access to the dangerous parts, between and on either side of the obstructions, through the area which would have been covered by the fixed blanked beams.

Therefore, in the case of incomplete obstruction, the **effective** detection capability has been increased and the separation distance must be calculated using this increased value.

In the case of complete obstruction, it is not possible for a person to gain access to the dangerous parts of the machine through the area of the curtain which would have been covered by the fixed blanked beams. When the light curtain/obstruction is considered as a whole, the detection capability in the unobscured areas of the curtain is not **effectively** increased.

Fixed
Blanked
Beams

Dotted line shows
effective detection
capability near obstruction

Figure 4 - Incomplete Obstruction

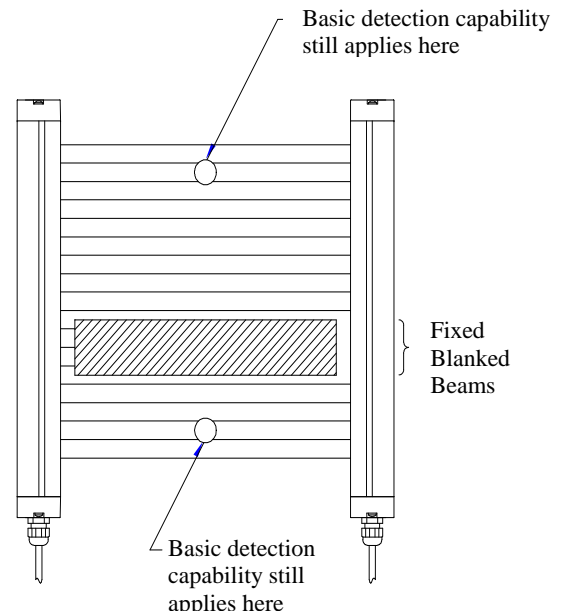

Figure 5 - Complete Obstruction

Therefore, the separation distance can be calculated using the **basic** detection capability value.

It is important that an obstruction originally considered as complete is not modified at a later date such that the use of the basic detection capability value is no longer valid. If this cannot be assured, it is recommended that the application is treated as an incomplete obstruction from the outset and the separation distance calculated accordingly.

NOTE: Any gaps between a complete obstruction and the light curtain units must not exceed the values recommended in EN294.

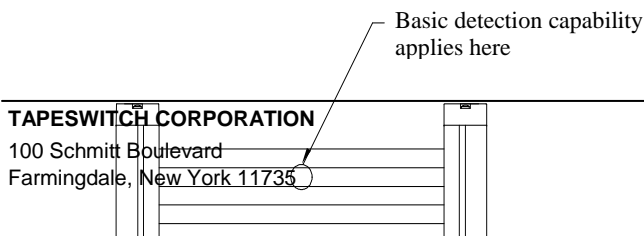

Figure 6 shows a combined obstruction where, due to the shape of the obstruction, part of the curtain is completely obstructed and part of the curtain is incompletely obstructed. In this case the complete and incomplete parts of the obstruction should be treated separately.

In all cases, if the obstruction is removed, the opposite mode monitoring will take effect and will cause a stop signal to be generated.

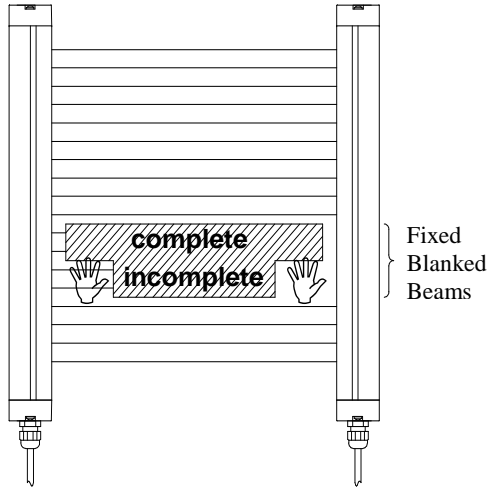

Figure 6 - Combined Obstruction

1.3.3 CALCULATION OF EFFECTIVE DETECTION CAPABILITY

The effective detection capability to be used for the purpose of calculating the separation distance can be determined as follows:

Case 1 Fixed blanking with complete obstruction: Basic detection capability applies.

Case 2 Fixed blanking with incomplete obstruction: Formula 1 applies.

Case 3 One or two beam floating blanking only: Formula 1 applies (see table 4 below).

Case 4 Fixed blanking with one or two beams floating blanking and complete obstruction: Formula 1 applies with $N_{fx} = 0$.

Case 5 Fixed blanking with one or two beam floating blanking and incomplete obstruction: Formula 1 applies.

NOTE: If there are a number of obstructions in the same curtain the calculation must be made for each obstruction and the largest value found should be used in the calculation of separation distance.

Basic Detection Capability	1 beam floating	2 beam floating
14mm	23mm	32mm
30 mm	47mm	64mm
70mm	120mm	170mm

Table 4

Full details of the calculation of separation distance can be found in the technical manual for the light curtain and in the ANSI Standard B11.19-1990.

For cases 2 and 5, if the number of beams which are fixed blanked (N_{fx}) is not clear the following procedure can be used:

1. Measure the largest obstruction, where it obscures the curtain.
2. Divide the measurement by the appropriate increment, I, shown in Table 3.
3. Add 0.25 to the answer **then** round up to the next integer.
4. Use this value for the term N_{fx} .

Example: A vertical light curtain with a basic detection capability of 30mm is incompletely obstructed by horizontal sheet supports with section 48mm x 48mm.

The value of I for a curtain with basic detection capability of 30mm is 17mm (from table 3).

48 divided by 17 gives 2.82
Adding 0.25 gives 3.07
Rounding up to next integer gives 4.
Using $N_{fx} = 4$ in Formula 1 gives:

$$D_e = 30 + 17 (4 + 0) = 98mm$$

Use this value for detection capability when calculating separation distance.

2. BC-4 PROGRAMMING FUNCTION

2.1 UNIT DESCRIPTION

The BC-4 unit has provisions for programming the blanking function of a B-Series system.

The BC-4 case has five indicators, two buttons, one reset key switch, and one program key switch. The front panel of the BC-4 is shown in figure 7.

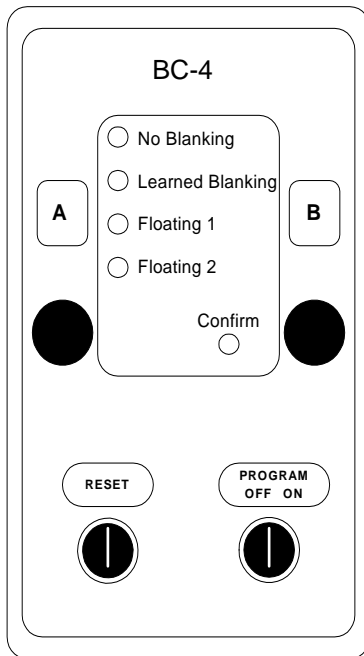

Figure 7

Four of the indicators are associated with the four types of blanking:

- no blanking
- learned (fixed) blanking
- 1 beam floating blanking
- 2 beam floating blanking

Because these can be used in combination there are six possible programmed modes:

- no blanking
- learned (fixed) blanking
- 1 beam floating blanking
- 2 beam floating blanking
- learned with 1 beam floating blanking
- learned with 2 beam floating blanking

2.2 PROGRAMMING INSTRUCTIONS

The basic programming sequence is described below and illustrated in Figure 8:

1. Turn the program key switch from the OFF position to the ON position. All the mode indicators will come ON with the current mode indicator(s) flashing.
2. To enter programming mode, press buttons A and B together for 3 seconds. The mode indicators will go OFF. Once the mode indicators go OFF, release both buttons and after a short period, the confirm indicator will come ON and then go OFF. Button B must be pressed within 1 second of the confirm indicator coming ON and released within 1 second of the confirm indicator going OFF.
3. If step 2 is followed correctly the indicators for the current mode will be ON steady. Pressing button A repeatedly will cycle the indicators through the possible blanking modes.
4. To program a particular mode, press buttons B for at least 3 seconds when the desired mode indicators are ON.
5. While the light curtain is programming the selected mode, the selected mode indicator(s) will flash. Once the selected mode has been programmed, the other indicators will come ON steady, and the programmed mode indicators will flash.
6. After a short period, providing the curtain is in an acceptable state, the outputs will come ON. The system is now in the initial state. Turn the program key switch from the ON position to the OFF position.

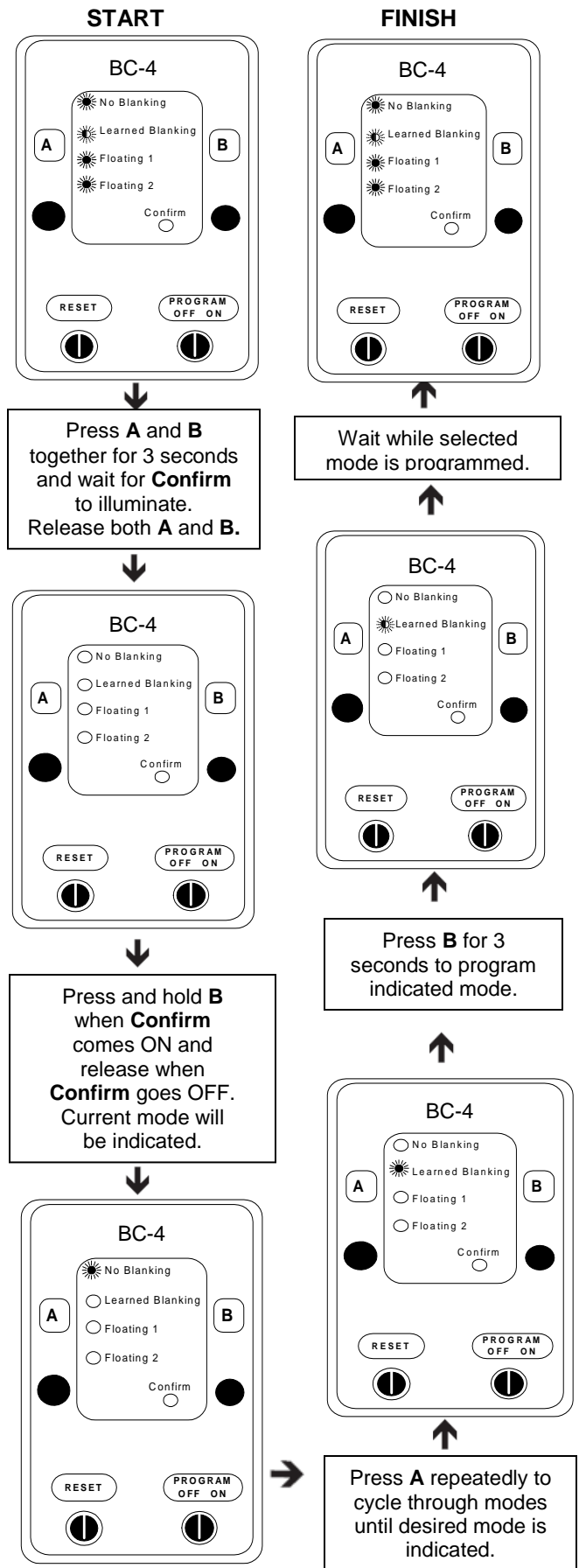
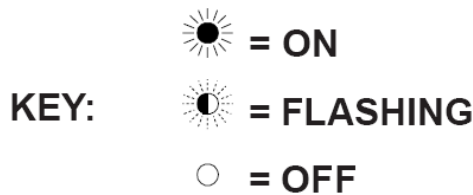

Figure 9

2.3 OPERATING CONSIDERATIONS

2.3.1 BC-4 PROGRAMMING OPERATION

1. Beam 1, the beam nearest the connector end of the emitter and receiver units, cannot be blanked in any way. If beam 1 is obscured, the outputs will go OFF.

2. When the BC-4 program key switch is switched to the "ON" position, check that all the mode indicators illuminate.

3. Once programming mode has been entered, if no buttons are pressed for a period of ten seconds, programming will automatically abort and the previously programmed mode will be resumed. Similarly, if an inappropriate sequence of button operations is performed the programming will automatically abort. Automatic aborting will be indicated by all the mode indicators illuminating for a period of five seconds.

4. The machine cannot be operated when the BC-4 is in program "ON" mode. It is recommended that the BC-4 program key switch key be held by a responsible person when not in use.

5. If no beams are obstructed, learned blanking will not program. If the selected mode **is** learned blanking or **includes** learned blanking, the light curtain will default to the selected mode **minus** learned blanking. For example, if learned blanking only is selected, the light curtain will default to no blanking; if learned blanking with 2 beam floating blanking is selected the light curtain will default to 2 beam floating blanking only.

6. If the light curtain is in test mode (indicated by the red indicator on the emitter unit being steadily lit), the programming unit will not function.

7. If the communication link between the light curtain and the BC-4 programming function is not functioning, all the mode indicators will flash while the program key switch is in the "ON" position.

2.3.2 CURTAIN OPERATION

When a light curtain is programmed for blanking of any type, the yellow indicator on the light curtain receiver unit will be steadily lit. This confirms that the light curtain has been programmed for some mode other than no blanking.

3. MANAGEMENT ISSUES

3.1 BLANKING TEST PROCEDURE

Immediately prior to programming the light curtain for learned (fixed) blanking (with or without floating blanking), it is essential that the light curtain be tested as follows:

1. With the light curtain in its intended position on the machine, but with no obstruction in place, program the light curtain for "NO BLANKING". Check that all the indicators of the BC-4 unit illuminate when the programming is initially switched on. A faulty indicator could lead to programming of the wrong mode.

If any indicator does not illuminate, **DO NOT USE THE PROGRAMMING UNIT UNTIL IT HAS BEEN REPAIRED.**

2. Perform the daily test on the light curtain system, as detailed in the light curtain technical manual, using the test piece supplied with the light curtain (i.e., the test piece with a diameter which is the same as the detection capability marked on the light curtain unit labels).

If this test fails, **DO NOT USE FIXED BLANKING UNTIL THE LIGHT CURTAIN HAS BEEN REPAIRED.**

3. If the test is passed, without moving the light curtain, fit the obstructions in place and program the desired blanking mode.

This test ensures that faulty beams, which may not be obscured by the obstruction, are not inadvertently blanked.

3.2 DETECTION CAPABILITY - TEST AND INDICATION

When blanking is in use, the detection capability can be affected such that the detection capability marked on the light curtain units is not correct. This also means that the test piece supplied with the light curtain is no longer suitable for performing the daily tests.

Previous sections of this manual describe how to determine the effective detection capability for any blanking situation.

A test piece will need to be obtained or produced to suit the effective detection capability, in order to perform the daily tests.

Also it is recommended that the current effective detection capability of a system be recorded and clearly displayed at the machine.

4.0 INTERFACE AND AUXILIARY UNITS

4.1 GENERAL

In applications where the two solid state outputs are not suitable for the machine control circuit, an interface unit must be utilized. This interface unit may be user supplied, provided it is compatible with the two solid state PNP outputs and has two channels. A number of manufacturers produce units containing circuits of this type. Care should be taken to ensure that the inputs of these units can accept the PNP outputs of the light curtain. The B-Series system checks that its outputs are functioning correctly by switching them off for 50 microseconds every 5.5 milliseconds. The interface unit must be designed to the same level of integrity as the B-Series in order to maintain the same overall level of safety.

Several Tapeswitch interface units are available which offer options in configuring the input power source, mounting package, and type of electrical interface desired. All of the units perform the actual switching of the electrical circuit of the dangerous machine using positively-guided safety relays. All of the AC powered interface units (BSRSA and BSRUA-2) provide the stepped down +24VDC power for the B-Series sensing units (emitter and receiver). The DC powered interface unit, SRUB, and SRUS is powered by an external +24VDC power supply and this supply *must also power the B-Series sensing units*. All of these interface units provide isolation from the low-amperage B-Series solid state outputs (0.5A each) and the potentially higher amperage required by the machine control circuitry. Each interface unit provides LED status indicators. All LEDs will be discussed in the description of the applicable interface unit.

4.1.1 METHODS OF INTERFACING

All of the interface units have a minimum of two safety outputs. These outputs are to be interfaced with the machine primary control elements (MPCEs). An MPCE is defined as an electrically-controlled element which directly controls the normal operating motion of a machine such that it is the last (in time) to operate when motion is initiated or arrested.

The safety output contacts of the interface unit must be connected to a machine's MPCEs in such a way that if either of the safety output relays is switched off, then the machine will be brought to rest, regardless of the state of the other relay.

This gives assurance that the failure of a single relay cannot prevent the machine from being stopped. The safety output relays are cross-monitored within the interface unit. This means any disparity between the two relays will be detected. The machine will be disabled until the cause of the disparity has been removed. Such a disparity could be the loss of signal on one of the two channels coming from the sensing unit. The interface will only allow the safety relays to move to the ON state if both channels are working correctly together.

All interface units are provided with indicator lamps which show the status of the interface. The number, color, meaning and location of the indicators may change with the type of interface. All interfaces however, have indicators which specifically show the commanded state of the output safety relays.

Both of these outputs must be used to take advantage of the inherent redundancy of the interface unit.

The two safety outputs are normally-open (NO). The outputs are closed when no obstructions are in the light curtain and no faults exist. Once the light curtain is broken the outputs open. The state of the output may remain open until a reset switch is applied (**MANUAL RESET**) or will automatically close (**AUTOMATIC RESET**) once the light curtain is cleared. Details of the resetting features are discussed in the individual interface sections to follow.

The safety outputs can be used in several ways, depending on the MPCEs found on the machine being guarded. MPCE is the abbreviation for Machine Primary Control Element. An MPCE is an electrically powered control device which directly controls the guarded machines motion and is the final device in the operating sequence when motion is either initiated or halted. This would be the main hydraulic control valve in a hydraulically controlled press. Some of the common arrangements are described below:

- Normal risk machine - These usually have a single MPCE. In this case both normally open safety outputs should be used together as shown in Figure 23.
- High risk machines - These should have 2 MPCEs. In some countries, it is customary for both MPCEs to operate in the same mode. In this case, each of the normally-open (NO) outputs controls a single MPCE. See Figure 24 (page 13) for an illustration of the type of interface. Any additional output contacts can be used for monitoring, e.g., as an input to a PLC.

To protect the contacts of the safety output relays from the effects of switching inductive loads, an appropriately rated power factor correction device must be installed for the MPCE coils. Figures 23 and 24 show Arc Suppressors used for this purpose. Arc Suppressors are user supplied.

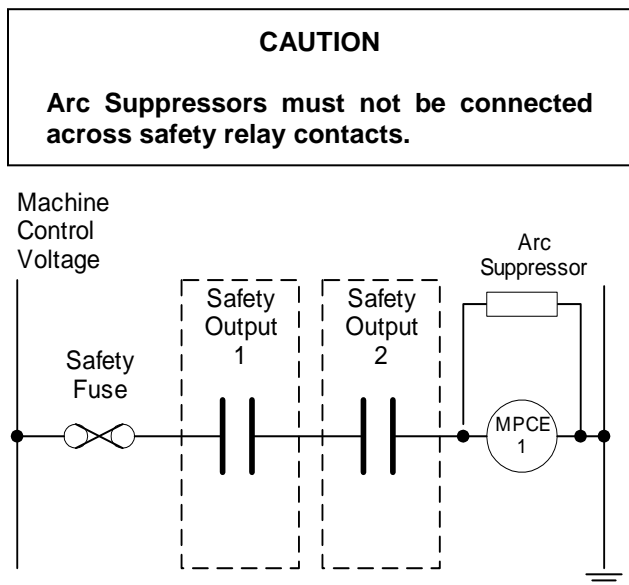

Figure 23 – Interfacing a Machine with 1 MPCE

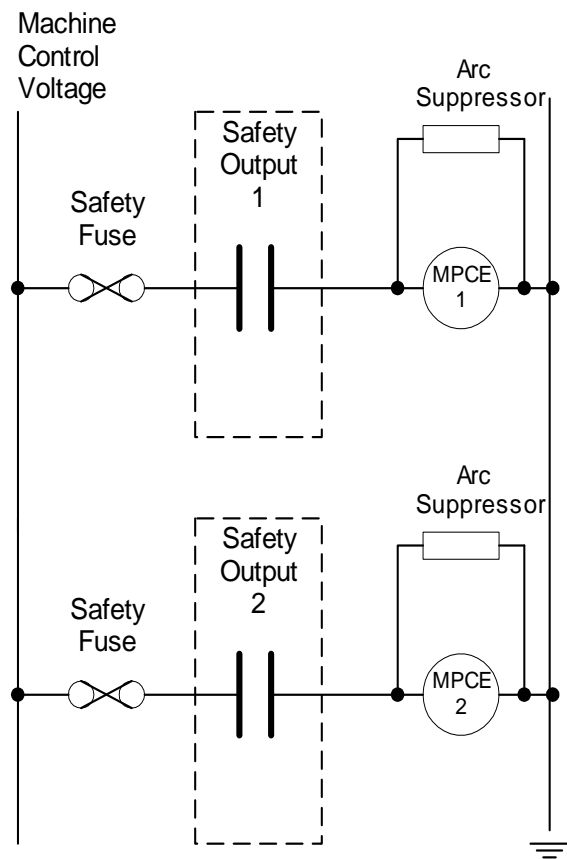

Figure 24 – Interfacing a Machine with Dual Identical PMCEs

SAFETY FUSES: It is good practice to protect the safety relays against welding due to a current surge. This can be done by current limiting designs in the machine’s controls, or by simple fusing as shown in Figure 23 and 24. The current through the safety output contacts should be limited to a level below that which could cause the contact to weld. Fuses with a current rating less than that of the output contacts should be used.

On the BC-4 Interface Unit, these safety (output protection) fuses are part of the unit. All of the other interface units do not provide safety fuses (output protection) and these fuses should be supplied externally by the user.

4.2 BC-4 INTERFACE UNIT

4.2.1 GENERAL DESCRIPTION

The BC-4 interface unit is designed as a stand alone control panel. It interfaces a B-Series sensing unit (emitter and receiver) with the machine’s controls. It is also equipped with a programming function - to be described later in this text.

4.2.2 OPERATIONAL SEQUENCE AND LED STATUS DESCRIPTION

When power is first applied to the light curtain system via the BC-4, insure that the program key switch is in the “OFF” position:

- A red LED (H3) on the BC-4 controller should illuminate indicating that the control unit has power.
- No power will be supplied to the emitter or receiver (sensing units), and the output status indicators in the BC-4 controller will not be illuminated. All of the outputs will be de-energized, and the output contacts will be open, until the reset has been initiated.
- Reset the system by the front panel key switch or the external remote reset (if used, see below for detail). After the reset switch is released, both the emitter and receiver (sensing unit) should have amber indicators illuminated which shows that power has been applied. If the sensing unit is properly aligned, the receiver should have a green LED illuminated which shows the light curtain is clear. If the receiver shows a red LED illuminated then the sensing unit is either not properly aligned, faulty or obstructed. Once the units are properly aligned and any obstructions are removed, the green LED should be illuminated and receiver LEDs follow the state of the light curtain (green indicates curtain clear and red indicates curtain is blocked, obstructed, or misaligned). With the green LED illuminated on the receiver, the output status indicator on the BC-4 controller should be green (H2). The output status indicator on the BC-4 controller will be red (H1) once the curtain is blocked or obstructed, or misaligned.

The redundant safety outputs follow the state of the light curtain: if the light curtain is clear; safety outputs 1 & 2 will be closed (energized); if the light curtain is obstructed, safety outputs 1 & 2 will be open (de-energized). Although the safety outputs reset AUTOMATICALLY, they will not reset (close/energize) if a fault exists.

The lockout contact will close (energize) once the reset sequence has been completed. It will remain closed at all times unless a fault has occurred or power has been removed. The lockout contact does not follow the state of the light curtain. Once the lockout condition occurs (loss of power or failure), it will be necessary to reset the system.

The monitoring output will follow the state of the safety outputs and should be used for non-safety functions (i.e. indication and status).

An external remote reset function can be added by connecting a normally-open momentary-contact switch to the terminal X2 between 1 and 2. (This will operate in conjunction with or replace the front panel keyed reset switch.)

4.2.3 MECHANICAL

Figure 25 shows the metallic enclosure size and mounting dimensions of the BC-4 interface unit. The dimensions are in inches. The BC-4 enclosure is rated for the operating environments found in most manufacturing plants. Figure 26 shows the internal view of the BC-4 printed circuit board.

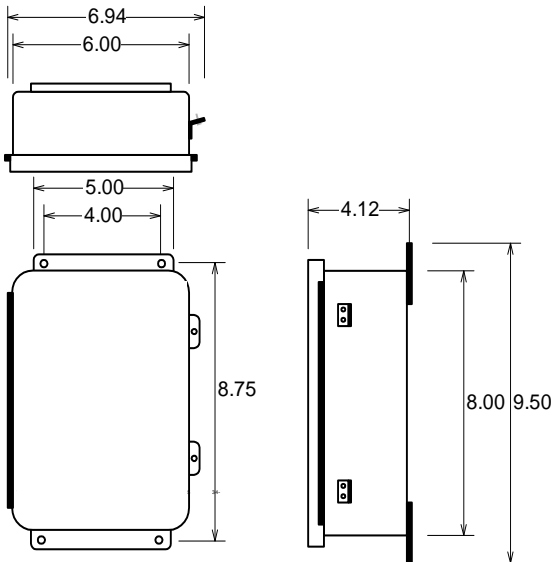

Figure 25 - BC-4 Interface Unit Outline and Dimensions

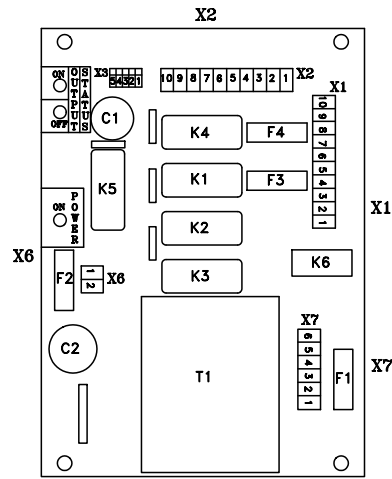
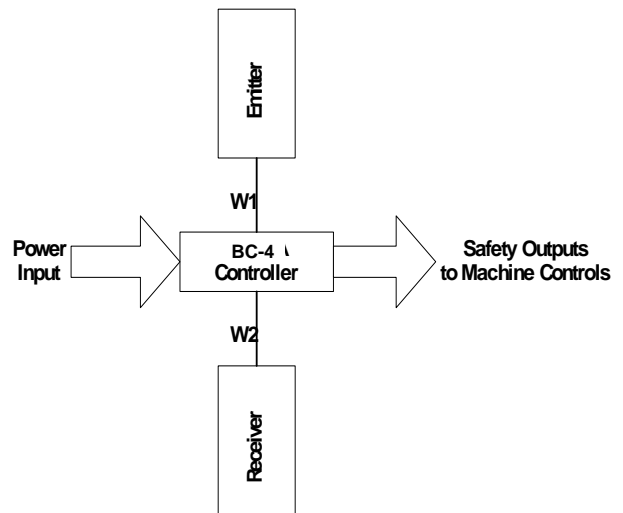

Figure 26 - BC-4 Interface Unit Internal View

4.2.4 ELECTRICAL CONNECTIONS

The BC-4 interface unit has four internal connectors, X1, X2, X6, and X7. Each terminal is mechanically suitable for (1) 2.5mm² (14 AWG) wire. Crimped ferrules or tinning must be used on all standard conductors. Figure 27 shows the system block diagram for the BC-4 controller. Terminal X7 is for ac input power. Terminal X6 is for the +24VDC power input. All connections between the BC-4 interface unit and the B-Series sensing unit (emitter and receiver) are made at terminal X2. All connections between the BC-4 interface unit and the machine's control are made at terminal X1.

See Figure 28 for details of terminal numbers and associated functions. The wire run list (WRL) shown in Figure 29 will give the proper terminal numbers and associated functions for the cabling between the B-Series sensing unit (emitter and receiver) and the BC-4 interface unit.



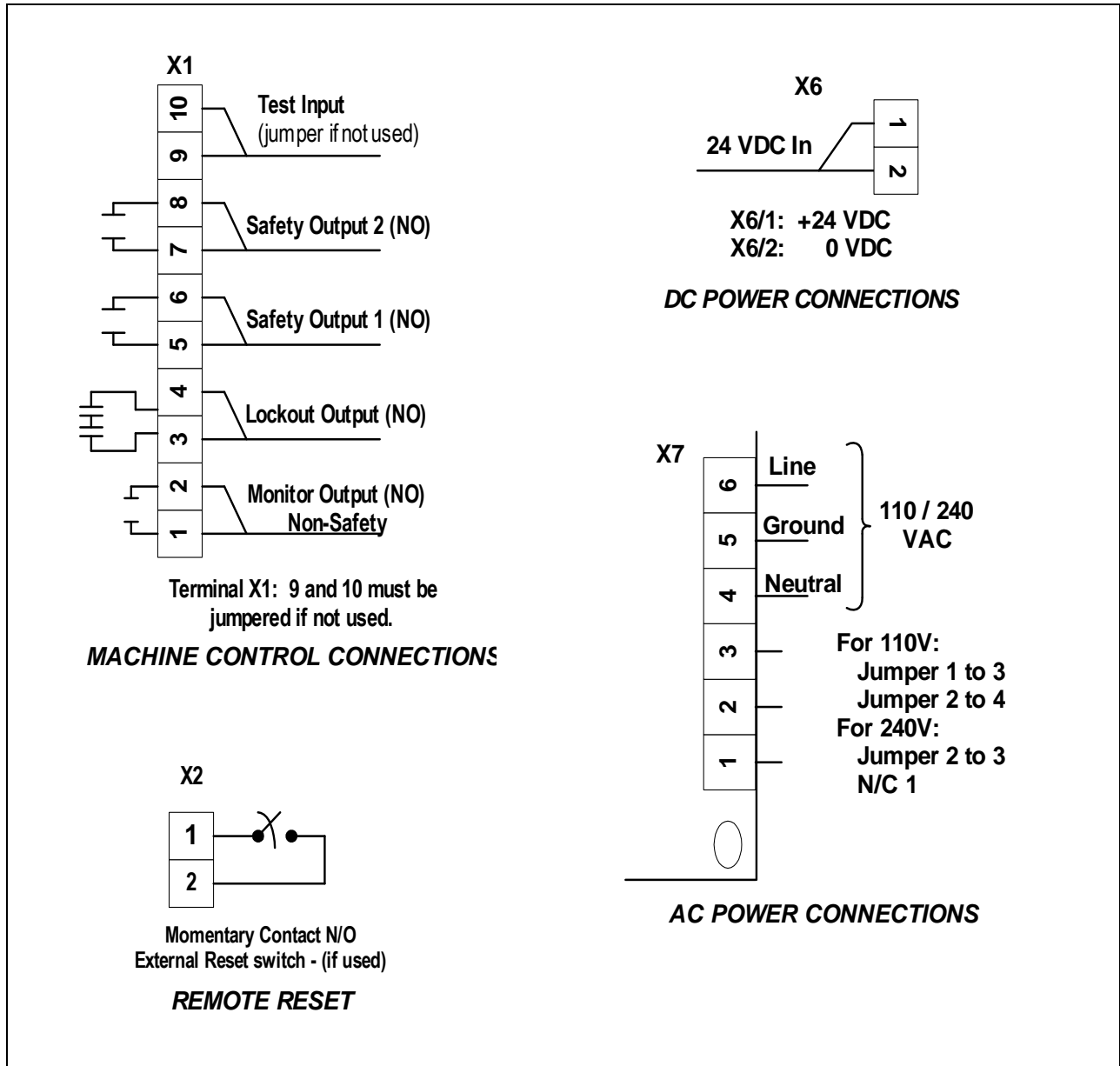

Figure 28 - BC-4 Terminal Numbers and Functions

NOTE: Connection from the emitter and receiver is made to terminal X2, see Figure 29 (page 16) for details.

Cable #	Cable Type	Color Code	Function	From	To
	RKT5-612/XX			Emitter 5 Pin Quick Disconnect	BSRSA Terminal X2
W1	"	Brown	+24VDC	1	10
W1	"	White	OV DC	2	9
W1	"	Blue	Test Out	3) Jumper 3 to 4, if not used	No Connection
W1	"	Black	Test In	4) Jumper 4 to 3, if not used	No Connection
W1	"	Gray	Ground	5	4
	RKT8-09/XX			Receiver 8 Pin Quick Disconnect	BSRSA Terminal X2
W2	"	White	OV DC	1	5
W2	"	Brown	24VDC	2	6
W2	"	Green	Ground	3	3
W2	"	Yellow	Output 1	4	7
W2	"	Gray	Output 2	5	8
W2	"	Pink	Data (-)	6) Isolate 6 & 7	No Connection
W2	"	Blue	Data (+)	7) Isolate 6 & 7	No Connection
W2	"	Shield	Ground	8	Ground

Figure 29 - Wire Run List for BC-4 (Reference Only)

The cables for the interface between the B-Series sensing unit (emitter and receiver) and the BC-4 unit are supplied separately for the BC-4. The emitter cable has five conductors with a gray insulated jacket. The receiver cable has eight conductors with a gray insulated jacket. The emitter and receiver cable assemblies are available in 5M, 10M, and 30M lengths and are supplied with a female connector on each end.

The metallic enclosure has two knockouts capable of accepting standard 3/4in conduit fillings. It is recommended that any high voltage connection made to the BC-4 control unit be made with suitable cabling and/or conduit protections. The connection between the BC-4 and the B-Series sensing unit (emitter and receiver) are non-hazardous, low-voltage signals and additional protection of these cables is not necessary. It is recommended that suitable fittings or cable grips be used to maintain the moisture integrity of the installation. Separation of the low voltage connections from the high voltage connections is also recommended. Local electrical codes should be observed.

4.2.5 FUSES

The BC-4 is equipped with four fuses: F1, F2, F3, and F4. See Figure 26 for the location of these fuses. Fuse F1 is a 500ma, 250VAC slow-blow type, and is intended to protect from potential shorts and surges on the high voltage side of the interface unit. Fuse F2 is a 1.2amp, 250VAC quick-blow type, and is intended to protect from potential shorts in the 24V low voltage circuitry of the interface unit. Fuses F3 and F4 are output protection fuses. These fuses are 3.15amp, 250VAC slow-blow type, and protect the safety output relay contacts against welding due to current surges or excess loading. Care should be taken to replace any fuses with the correct rating. While replacing any fuses, particular attention should be given to the fuse holder. Excess stress on the fuse holders during replacement can lead to intermittent connections which may cause nuisance tripping and/or a nuisance lock out condition.

4.2.6 TEST INPUT

The BC-4 interface provides a test input. This input is used to check the interface between the photo-electric safety system and the machine. The input electrically simulates an obstruction of the light curtain. While in the normal or run mode, this input would be closed. This input is opened and closed during the test period. The machine’s control logic can verify that the safety output relays did in fact cycle, thereby exposing any fault before the next machine cycle. This test input should be applied during a safe part of the machine cycle, or at the end of the cycle. While this input is applied (opened), the power is removed from the B-Series sensing unit (both emitter and receiver). Once the input is removed (closed), power is once again supplied to the sensing unit. The sensing units may take a few seconds to re-synchronize, and consequently the safety outputs will take a few seconds to resume their normal state. The input device should be a dry contact which is closed during the run mode and momentary opened during the test mode. The test input is located on terminal XI at connections 9 and 10. If this input is not utilized, a jumper should be installed on these terminals. (This feature is seldom used and, therefore, a removable jumper is installed at the factory.)

4.2.7 MONITOR/AUXILLIARY OUTPUT

A non-safety monitor/auxiliary output is also provided. This output is a solid state relay output which is closed when the light curtain is clear and is open when the light curtain is obstructed, a fault exists, or a lockout condition is present. This output is located on terminal X1 at connections 1 and 2. This output can be used for display and status indication. It must not be used for safety-related machine control and switching functions.

4.2.8 BC-4 TECHNICAL SPECIFICATIONS

Specifications		Data	Tolerance
Supply Voltages		110 VAC 240 VAC	+ 10% - 15%
		24 VDC	+ 10% - 15%
Safety Outputs	Type	Positively guided, forced contact	
	Contacts	Two (NO) for use with FSDS (Final Switching Devices) One (NO) for lockout use, (Secondary Switching Device)	
	Rating	4.0 A resistive load @ 240VAC 4.0 A resistive load @ 24VDC 5 Hz maximum rate	
	Fusing	Two (2), 3.15Amp, internal	
Monitor/Auxiliary Output		0.5 Amp, 48 VDC 10 Watt max	
Dimensions		9.50 in. (241mm) high 7.00 in. (178mm) wide 4.12 in. (105mm) deep	
Weight		Approximately 7 lbs.	
Enclosure Rating		NEMA TYPE 1 (standard) NEMA TYPE 12 (available)	
Connecting Terminals	Type	Captive terminals, with removable headers	
	Capacity	One 2.5mm sq. (AWG 14)	

