



PSSU Control Unit Installation Instructions

INTRODUCTION

PSSU control units are designed to be used with Tapeswitch pressure-sensitive sensors, such as ribbon switches, sensing edges, bumpers, and presence-sensing mats, to form a complete safety system. A number of sensors can be connected in series.

CONTROL UNIT TYPES

Four versions of the control unit are available which differ only in their type of enclosure and supply voltage. The PSSU/1 control unit is housed in a DIN rail-mounting enclosure with 16 integral terminals and operates from a 110 or 240 Vac supply.

The PSSU/2 control unit uses the same enclosure but operates on a 24 Vdc supply. Both of the above units are intended to be fitted inside an existing electrical enclosure on the machine. This existing enclosure must be sealed to a minimum rating of IP54.

The PSSU/3 control unit uses a polycarbonate enclosure sealed to IP67 and operates from a 110 or 240 Vac supply.

The PSSU/4 control unit uses the same IP67 enclosure as the PSSU/3 unit but operates from a 24 Vdc supply. Both the above units are intended to be fitted either externally or inside an existing enclosure on the machine.

SAFETY INTEGRITY

All PSSU control units exceed the requirements of safety integrity level 2 as defined by DIN 31006-1. The control units are self-monitoring, which means that any faults in safety critical components will be detected and will render the machine inoperative until the fault is rectified. However, the safety integrity of the system as a whole depends on the safety integrity of the sensor used, in addition to the proper installation, interface, and application.

PRINCIPLE OF OPERATION

The control units contain the power supply for the system, the safety output relays and the reset circuit. Figure 1 shows the principle of operation. A 24 Vdc power supply is taken from the control unit to the switching elements in the sensor(s): +V_e to one conductor, -V_e to the other conductor, and back to the control unit where it supplies power to the output relays.

The output contacts of the safety relays are only closed when the output relays are energized. When the sensor(s) is actuated, the 24 Vdc power supply to the output relays is shorted out causing them to de-energize. Furthermore, if the power supply to the output relays is interrupted or shorted out by a fault in the sensor(s) wiring or in the switch elements, power to the output relays will be lost, the relays will de-energize and the output contacts will open. The reset circuit provides start and restart interlock functions as follows:

Start Interlock - When power is applied to the system, the output relays cannot be energized until a reset signal has been applied and removed.

Restart Interlock - Once the sensor(s) has been actuated and the output relays have de-energized, they cannot be energized again until a reset signal has been applied and removed.

Reset will be prevented while the sensor is actuated, if there is a fault in the reset input circuit or if the two output relays are in disparity. The safety output contacts of the control unit are connected to the machine primary control element(s) in such a way that if either of the safety output relays is de-energized then the machine will be brought to rest regardless of the state of the other relay.

NOTE: A machine primary control element or MPCE is defined as an electrically-controlled element which directly controls the normal operating motion of a machine such that it is the last (in time) to operate when motion is initiated or arrested.

In addition, where the machine control system has two MPCEs, these devices can be monitored by connecting normally-closed auxiliary contact from each MPCE in series with the reset input. Disparity between the two MPCEs will prevent a reset.

INSTALLATION WARNING

Tapeswitch Safety Systems are designed to protect operators working at or near dangerous machines. They can only perform that function if they are correctly fitted and interfaced to a suitable machine. Every effort has been made to provide comprehensive and accurate information. It is the responsibility of the user to ensure that all persons involved in the installation of the product have the knowledge, training and experience necessary and that they are fully conversant with all laws, rules, regulations and codes of practice at their task.

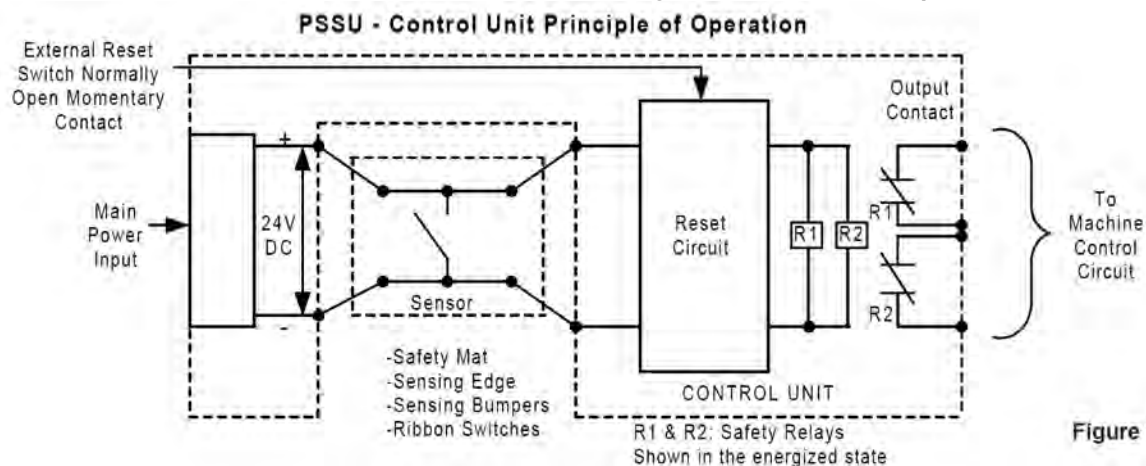

Figure 1

MECHANICAL

PSSU/1 and PSSU/2 Control Units - should be mounted in the machine control unit on standard 'top hat' terminal rail type DIN EN 50 022-35. The machine control unit must provide sealing to IP54 according to IEC 529. The dimensions of these two units are shown in Figure 2.

PSSU/3 and PSSU/4 Control Units - should be mounted on a permanent part of the machine in a position which keeps cabling to a minimum and provides sufficient protection from damage by passing traffic but allows adequate access for servicing. The dimensions of these units and the position of mounting holes are shown in Figure 3.

It will be necessary to punch or drill cable entry holes in the enclosure. These holes should be made in the top and bottom surfaces of the enclosure. It is recommended that the printed circuit board (PCB) assembly be removed while these holes are made. Ensure that the PCB assembly is refitted in its original orientation. For sensors with two 2-wire cables, six holes will be required. For a sensor with a single cable, five holes will be required. See Figure 4 for hole positions.

One hole should be used for (each of) the sensor cable(s), one for the mains supply cable, one for each of the safety output cables, one for the reset input cable and one for the monitor output cable. The holes should be 20 mm diameter to accept PG13.5 cable glands. Six cable glands are supplied with the unit which will accept cable of 5-9 millimeter diameter. If other cable glands are used, they must provide sealing to at least IP54 according to IEC529.

The exact cabling requirements are at the discretion of the installer and depend to a large extent on the siting of the various control system elements and whether the monitor output is used. Generally it is recommended that high voltage cables are routed away from low voltage cables.

RESET INPUT DEVICE

A momentary action, normally-open switch, preferably a 22mm industrial pushbutton, should be used to provide the reset input. The switch should be housed in a suitable enclosure and should be mounted in such a position that it is safe from damage by passing traffic and such that the person operating the switch can see all of the dangerous area.

ELECTRICAL

GENERAL - The connections for each of the control units are shown in Figures 5, 6, 7 and 8. Crimped ferrules should be fitted on all stranded wires. It is recommended that electrical installation be performed in the order described below.

SENSOR(S) CONNECTION - Connect the sensor cables to the control unit taking particular care that there are no stray strands which could cause a short between adjacent terminals. A number of sensors can be connected in series, see figures 13-16 for details and limitations. When connecting a number of sensors in series, the PSSU Controller treats these "combined" sensors as a single sensor. When any one of the sensors is actuated the output relays de-energize.

POWER CONNECTION - Connect mains power to the control unit. For AC operation on the PSSU/1 and the PSSU/3 units, jumpers will need to be fitted to select the appropriate voltage. The power consumption is 6 VA maximum.

RESET INPUT CONNECTION - Connect the reset input to the control unit. If the machine has two MPCEs, a pair of normally closed auxiliary contacts from each MPCE can be connected in series with the reset input as shown in Figure 9. This provides cross-monitoring of the MPCEs such that if they are in disparity due to a fault, reset will be prevented until the fault is rectified.

The reset input can also be used to provide a test input. This is often used in higher risk applications where the actuation of the safety device is simulated every machine cycle to reveal faults in the machine interface. This test input can be provided by connecting a normally open contact in parallel with the reset switch as shown in Figure 10.

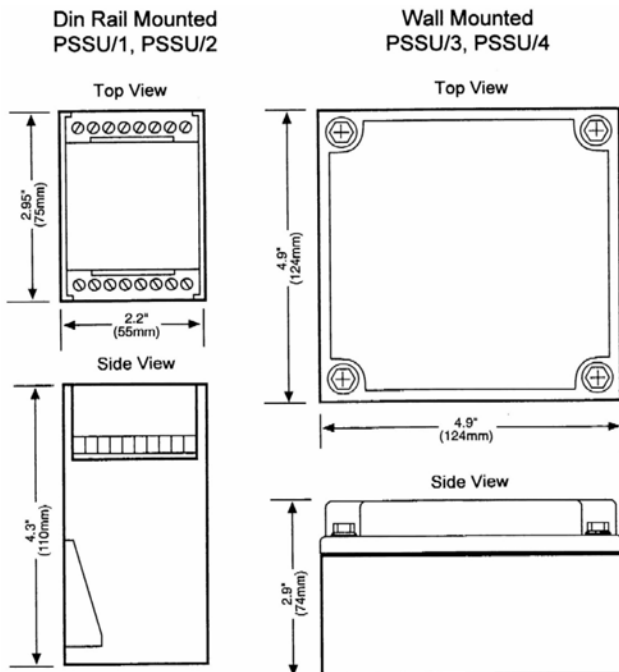

Figure 3

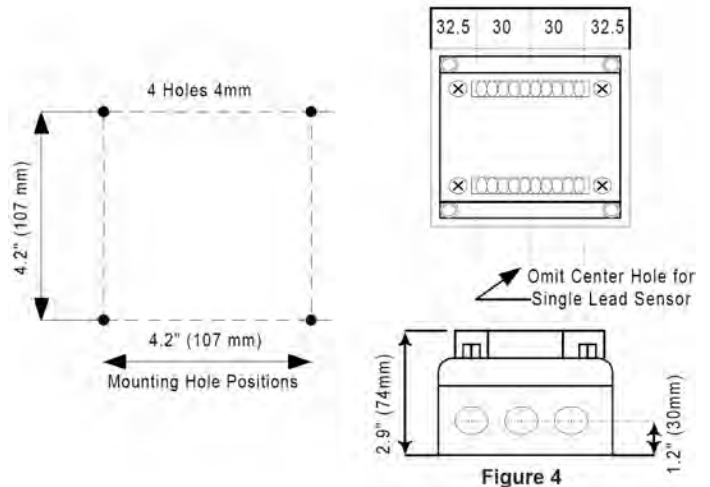

Figure 4

SAFETY OUTPUT CONNECTION

Two normally-open safety outputs are provided. In low to medium risk applications, the machine is normally provided with a single MPCE. In such cases, both safety outputs should be connected in series with the MPCE coil as shown in Figure 11. If the machine is fitted with two MPCEs one safety output should be connected in series with each MPCE coil as shown in Figure 12.

To protect the contacts of the safety output relays from the effects of switching inductive loads, arc suppressors should be fitted in parallel with the MPCE coils as shown in Figures 11 and 12. Arc suppressors must not be fitted across the safety relay contacts.

To protect against the possibility of both safety outputs welding in, due to an overcurrent fault in the machine circuit, 2A fuses should be fitted in series with the MPCE coils as shown in Figures 11 and 12. This limits the current through the safety output contacts to well below that which could cause the contacts to weld.

MONITOR OUTPUT (PSSU/3 and PSSU/4)

The monitor output is a change-over volt-free relay output. The monitor relay is energized when the safety output relays are energized. The monitor output can be used as an input to a machine control device such as a programmable logical controller (PLC) to signal that the sensor has been actuated.

NOTE: The monitor output is not a safety output and must not be used in the machine stop circuit.

INITIAL CHECKING

The system can be checked at this point as follows:

- (a) Check that the sensor is clear.
- (b) Apply power to the control unit. **DO NOT APPLY POWER TO THE MPCEs.** The POWER ON (RED) and SENSOR CLEAR (GREEN) indicators should be lit. The RESET ON and OUTPUT ON indicators should be off.
- (c) Press and hold the reset button. The RESET ON (AMBER) indicator should illuminate. The reset relay should be heard energizing.
- (d) Release the reset button. The RESET ON indicator should go off, and the OUTPUT ON (GREEN) indicator should illuminate.
- (e) Actuate the sensor. The SENSOR CLEAR and the OUTPUT ON indicators should go off.

If the system operates as described above, the installation can be completed.

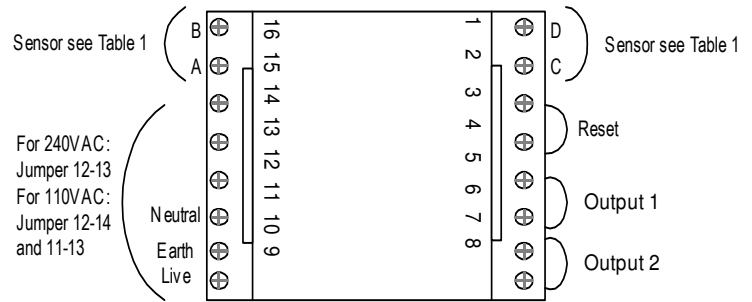

Figure 5 PSSU/1 Connection Details

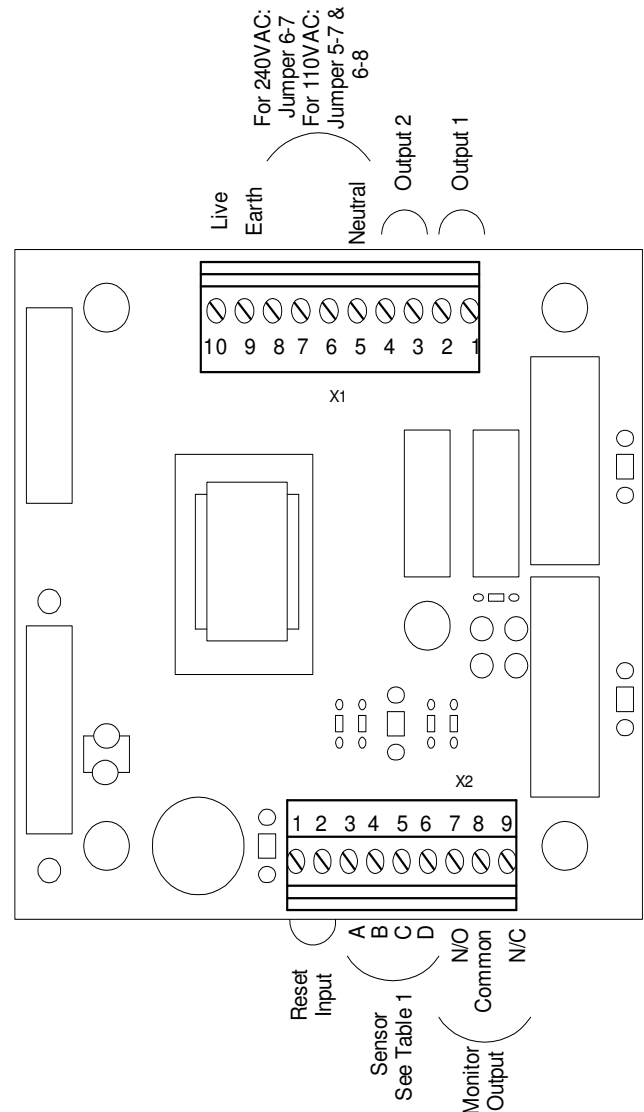

Figure 7 PSSU/3 Connection Details

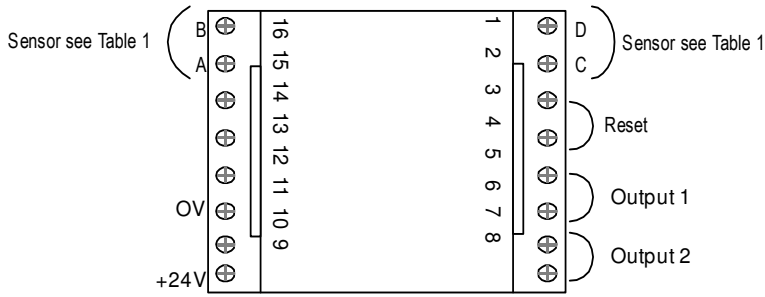

Figure 6 PSSU/2 Connection Details

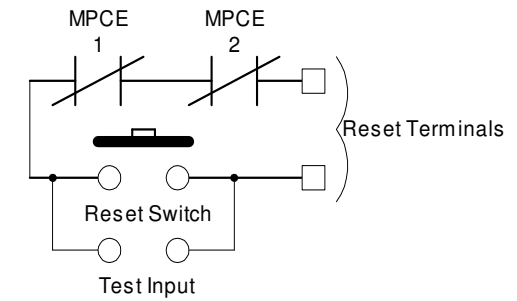

Figure 10 Connection of Test Input

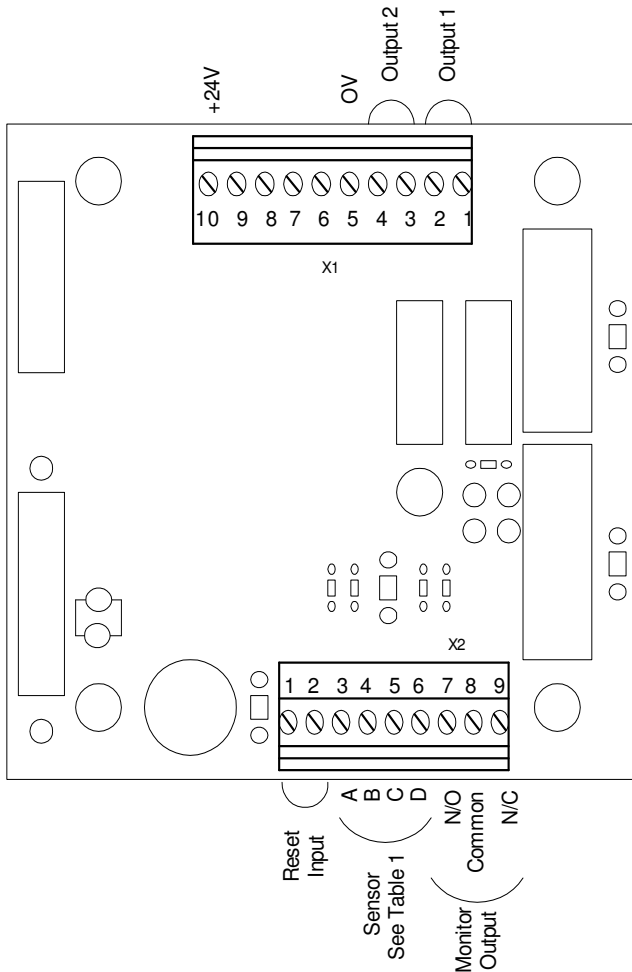

Figure 8 PSSU/4 Connection Details

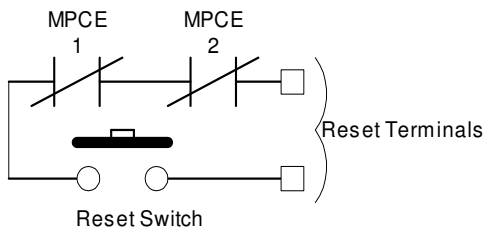

Figure 9 Cross-monitoring of MPCE's

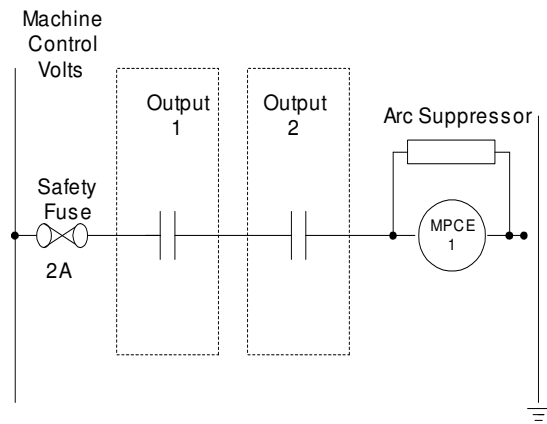

Figure 11 Safety Output Connection (single MPCE)

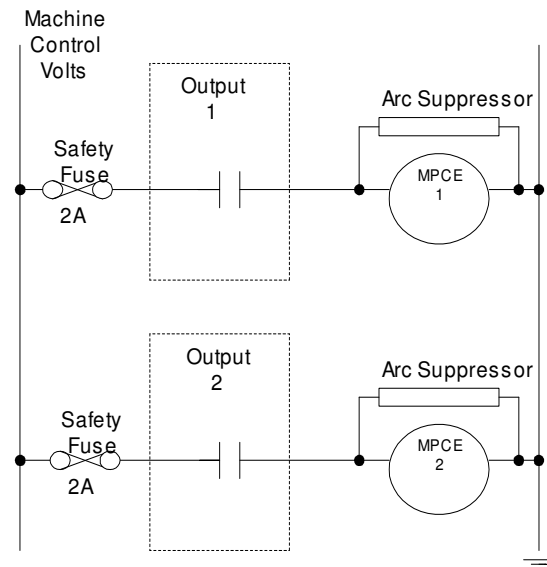

Figure 12 Safety Output Connection (two MPCE)

Table 1

SENSOR TYPE	SENSOR CONNECTION			
	A	B	C	D
CKP and Armormats	Black	Red	Yellow	White
Mats, Edges, and Ribbon Switch	Black 1	White 1	Black 2	White 2
Any Edge or Ribbon Switch	Ribbed 1	Smooth 1	Ribbed 2	Smooth 2

Table 2

	A	B	C	D	Terminal Numbers
PSSU/1 & 2	15	16	2	1	
PSSU/3 & 4	3	4	5	6	

TECHNICAL SPECIFICATIONS

Safety Grade	2 (DIN 31006-1)
Power Consumption	6 VA
Response Time	10 ms
Temperature Range: Operating Storage	0 to 50 degrees C -20 to 70 degrees C
Reset Function	Fitted as Standard
Supply Voltage: PSSU/1, PSSU/3 PSSU/2, PSSU/4	110/240 Vac 24 Vdc
Safety Outputs: Device Type Contact Type/Quantity Contact Rating	Safety Relay, Force-Operated Contacts 2 x Normally Open 5 A @ 240 Vac 5 A @ 24 Vdc } Resistive 0.75 A @ 50 Vdc } Load 1 A @ 24 Vdc } Inductive 0.35 A @ 50 Vdc } Load
Switching Frequency	5 Hz
Monitor Output (PSSU/3 & PSSU/4 Only) Device Type Contact Type/Quantity Contact Rating	Standard Relay 1 x Changeover 5 A @ 240 Vac
Enclosure: Protection Rating PSSU/1 & PSSU/2 PSSU/3 & PSSU/4 Terminal Capacity Material	IP20 IP67 2.5 mm ² Polycarbonate

INTERCONNECT DIAGRAMS, DAISY CHAINED/SERIES CONNECTION

Multiple Mats with 4 Conductor Standard Color Coded Lead Wire - Figure 13

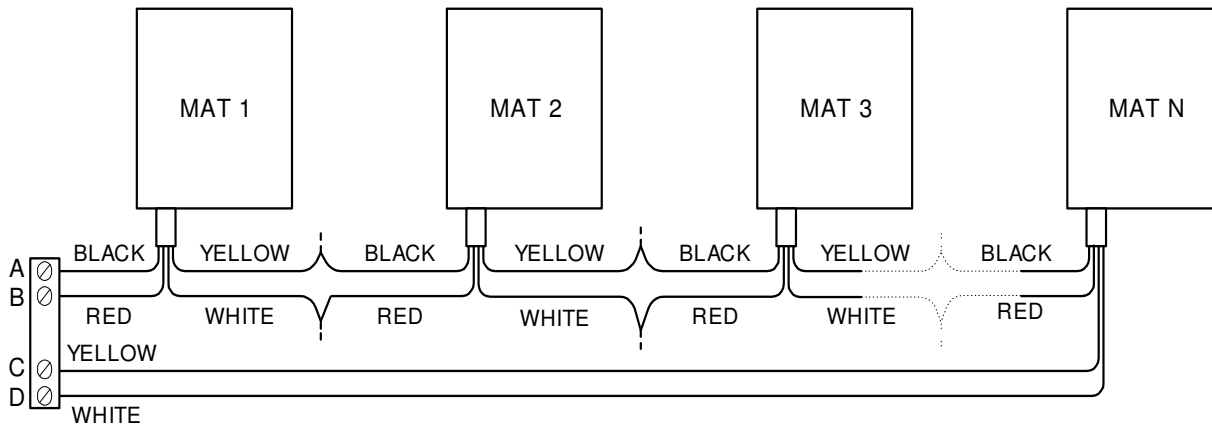

NOTE: Maximum Number of Mats Limited to 100 Square Feet

Multiple Mats with Optional 2 Conductor Standard Color Coded Lead Wire - Figure 14

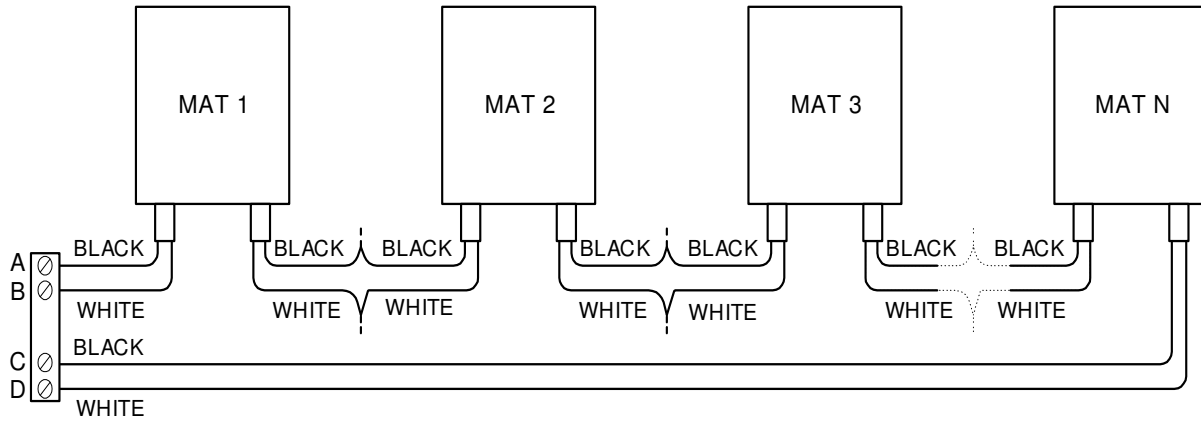

Multiple Sensing Edges, Bumpers and Ribbon Switches with Color Coded Wire - Figure 15

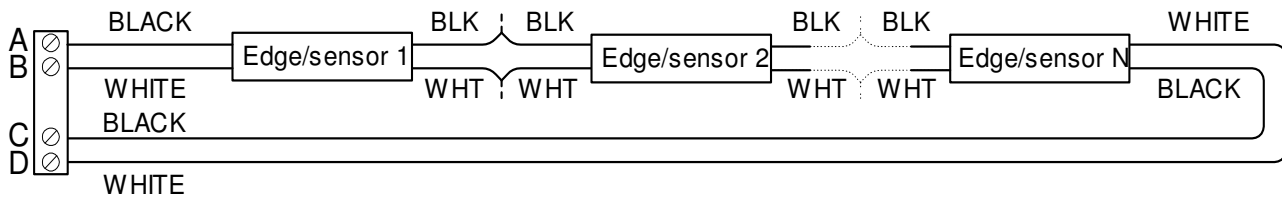

Edges and Bumpers Can Be Ordered with Lead Wire Exiting Both Ends to Facilitate Easy Series Connection

NOTE: Maximum Number of Edges, Bumpers, and Ribbon Switches Limited to 200 Feet

Multiple Sensing Edges, Bumpers and Ribbon Switches with Non-Color Coded Zip Cord Wire - Figure 16

