



PRSU/2 Safety Interface Controller

Installation Instructions

1. INTRODUCTION

Tapeswitch PRSU/2 control units are designed to be used with Tapeswitch pressure sensitive sensors to form a complete safety system. Sensors may take the form of safety mats, sensing edges, ribbon switches or bumpers. Full system installation instructions are supplied with the sensors.

2. PRODUCT DESCRIPTION

The unit operates from a 24 Vac/dc supply. From this is derived a current-limited 24 Vdc supply. The sensor and control circuit operate from this current-limited supply. The unit is housed in a DIN rail mounting enclosure with 12 integral terminals. This unit is intended to be mounted in an existing electrical enclosure on the machine. This existing enclosure must be sealed to a minimum rating of IP54. See Figure 2 for unit dimensions.

3. SAFETY INTEGRITY

Tapeswitch PRSU/2 control units exceed the requirements of safety integrity level 2 as defined by DIN 31006-1. The control units are self-monitoring, which means that any faults in safety critical components will be detected and will render the machine inoperative until the fault is rectified.

However, the safety integrity of the system as a whole depends on the safety integrity of the sensor used. See information supplied with sensor for further details.

4. PRINCIPLE OF OPERATION

The control unit contains the power supply for the system, the safety output relays and the reset circuit. A 24 Vdc power supply is taken from the control unit to the switching elements in the sensor(s), +ve to one conductor, -ve to the other conductor, and back to the control unit where it supplies power to the output relays. The output contacts of the safety relays are only closed when the output relays are energized. When the sensor is actuated, the 24 Vdc power supply to the output relays is shorted out causing them to de-energize. Furthermore, if the power supply to the output relays is interrupted or shorted out by a fault in the sensor wiring or in the switch elements, power to the output relays will be lost, the relays will de-energize and the output contacts will open.

The unit provides a manual or auto reset function.

In manual reset mode the reset function provides start and restart interlock functions as follows:

START INTERLOCK - When power is applied to the system, the output relays cannot be energized until a reset signal has been applied.

RESTART INTERLOCK - Once the sensor has been actuated and the output relays have de-energized, they cannot be energized again until a reset signal has been applied.

In auto reset mode the output relays will be energized whenever power is applied to the system and the sensor is clear.

In manual or auto reset mode, reset will be prevented if the sensor is actuated, if there is a fault in the reset input circuit, or if the two output relays are in disparity.

The safety output contacts of the control unit are connected to the machine primary control element(s) in such a way that if either of the safety output relays is de-energized then the machine will be brought to rest regardless of the state of the other relay.

NOTE: A machine primary control element or MPCE is defined as 'an electrically controlled element which directly controls the normal operating motion of a machine such that it is the last (in time) to operate when motion is initiated or arrested'.

In addition, where the machine control system has two MPCE's, these devices can be monitored by connecting normally closed auxiliary contacts from each MPCE in series with the reset input. Disparity between the two MPCE's will prevent a reset.

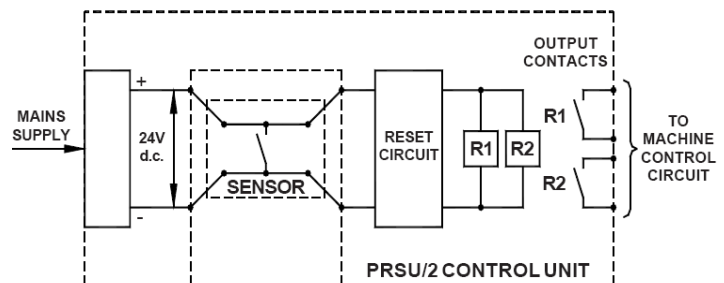

Figure 1 – Principle of Operation

5. INSTALLATION

WARNING

TAPESWITCH SAFETY SYSTEMS ARE DESIGNED TO PROTECT OPERATORS WORKING AT OR NEAR DANGEROUS MACHINES. THEY CAN ONLY PERFORM THAT FUNCTION IF THEY ARE CORRECTLY FITTED AND INTERFACED TO A SUITABLE MACHINE. EVERY EFFORT HAS BEEN MADE TO PROVIDE ACCURATE AND COMPREHENSIVE INFORMATION, BUT IT IS THE RESPONSIBILITY OF THE USER TO ENSURE THAT ALL PERSONS INVOLVED IN THE INSTALLATION OF THE PRODUCT HAVE THE KNOWLEDGE, TRAINING AND EXPERIENCE NECESSARY, AND THAT THEY ARE FULLY CONVERSANT WITH ALL LAWS, RULES, REGULATIONS AND CODES OF PRACTICE PERTAINING TO THEIR TASK.

5.1 MECHANICAL

5.1.1 GENERAL

The PRSU/2 control units should be mounted in the machine control unit on standard 'top hat' terminal rail type DIN EN 50 022-35. The machine control unit must provide sealing to IP54 according to IEC 529. The dimensions of the unit are shown in Figure 2.

The exact cabling requirements are at the discretion of the installer and depend to a large extent on the siting of the various control system elements. Generally it is recommended that high voltage cables are routed away from low voltage cables.

5.1.2. RESET INPUT DEVICE

A momentary action, normally open switch, preferably a 22mm industrial pushbutton, should be used to provide the reset input. The switch should be housed in a suitable enclosure and should be mounted in such a position that it is safe from damage by passing traffic and such that the person operating the switch can see all of the dangerous area.

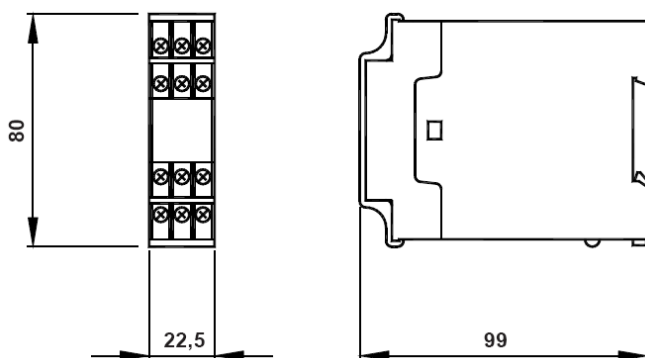

Figure 2

5.2 ELECTRICAL

5.2.1 GENERAL

The connections for the PRSU/2 control unit are shown in Figure 3. Crimped ferrules should be fitted on all stranded wires. It is recommended that electrical installation is performed in the order described below.

5.2.2 SENSOR CONNECTION

Connect the sensor cables to the control unit in accordance with Table 1, taking particular care that there are no stray strands which could cause a short between adjacent terminals.

5.2.3 POWER CONNECTION

Connect +24V to terminal A1 and 0V to terminal A2 as shown in figure 3. The maximum power consumption is 2.5VA.

5.2.4 RESET INPUT CONNECTION

For auto reset mode connect a link across terminals S33 & S34 as shown in fig.4.

For manual reset mode connect a normally open switch across terminals S33 & S34 as shown in fig.5.

If the machine has two MPCEs, a pair of normally closed auxiliary contacts from each MPCE can be connected in series with the reset input as shown in Figure 6. This provides cross-monitoring of the MPCEs such that if they are in disparity due to a fault, reset will be prevented until the fault is rectified.

5.2.5 SAFETY OUTPUT CONNECTION

Two normally open safety outputs are provided. In low to medium risk applications the machine is normally provided with a single MPCE. In such cases both safety outputs should be connected in series with the MPCE coil as shown in Figure 7. If the machine is fitted with two MPCEs, one safety output should be connected in series with each MPCE coil, as shown in Figure 8.

To protect the contacts of the safety output relays from the effects of switching inductive loads, it is recommended that arc suppressors should be fitted in parallel with the MPCE coils as shown Figures 7 and 8. Arc suppressors must not be fitted across the safety relay contacts.

To protect against the possibility of both safety outputs welding in, due to an overcurrent fault in the machine circuit, 2A fuses should be fitted in series with the MPCE coils as shown in Figures 7 and 8. This limits the current through the safety output contacts to well below that which could cause the contacts to weld.

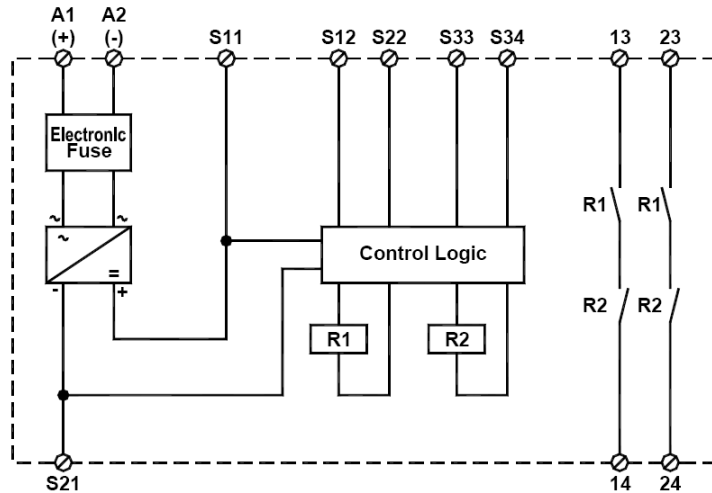

Figure 3

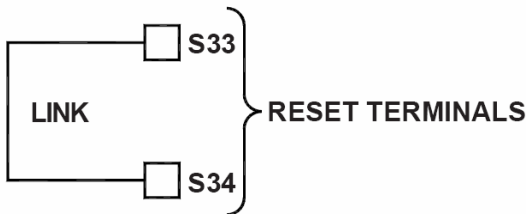

Figure 4 – Auto Reset

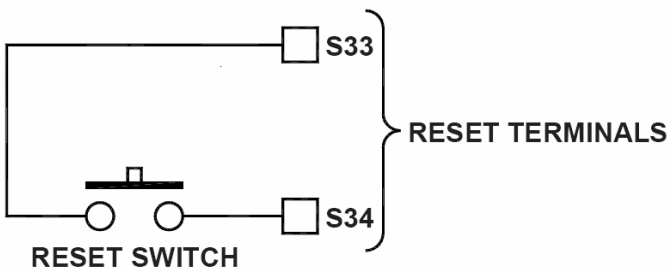

Figure 5 – Manual Reset

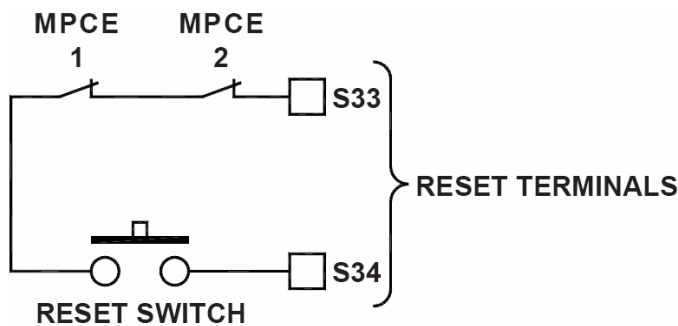

Figure 6 – Cross-Monitoring of MPCEs

SENSOR TYPE	SENSOR CONNECTION			
	S11	S21	S12	S22
CKP/S1 (single lead)	Black	Red	Yellow	White
CKP/S1 (dual lead)	Black, 1	White, 1	Black, 2	White, 2
Tapeswitch Sensor: Edge / Switch / Mat (Dual Leads)	Ribbed, 1 or Black, 1	Smooth, 1 or White, 1	Ribbed, 2 or Black, 2	Smooth, 2 or White, 2
Tapeswitch Sensor: Edge / Switch / Mat (Single Lead)	Ribbed, 1 or Black, 1	Smooth, 1 or White, 1	Link to S11	Link to S21

Table 1

5.3 INITIAL CHECKING

The system can be checked at this point as follows:

- (a) Check that the sensor is clear.
- (b) Apply power to the control unit. **DO NOT APPLY POWER TO THE MPCEs.** The POWER ON indicator should be lit, the CHANNEL 1 and CHANNEL 2 indicators should be off.
- (c) Activate the reset button. The CHANNEL 1 and CHANNEL 2 indicators should illuminate.
- (d) Actuate the sensor. The CHANNEL 1 and CHANNEL 2 indicators should go off.

If the system operates as described above, the installation can be completed. Before putting the machine into use the complete system should be commissioned as described in the sensor manual. If the safety system does not operate as described above, refer to the sensor manual for the fault finding procedure.

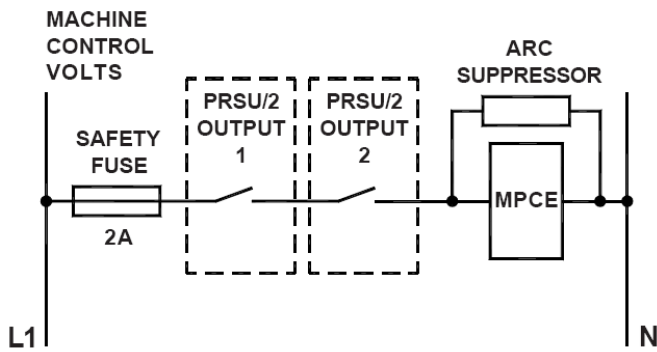

Figure 7 – Safety output connection (single MPCE)

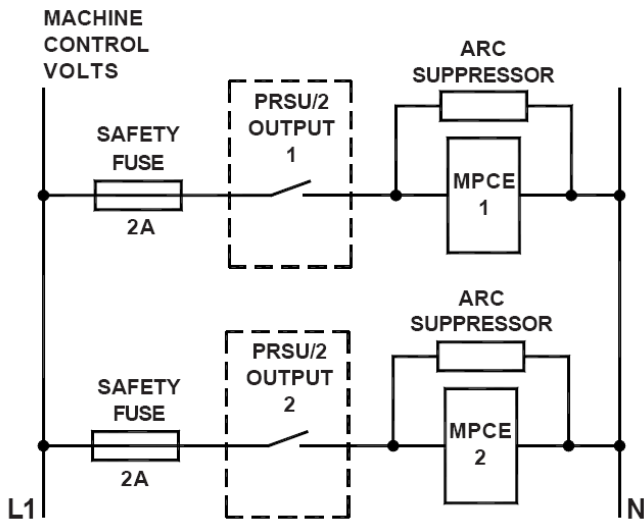

Figure 8 – Safety output connection (two MPCEs)

6. TECHNICAL SPECIFICATION

Safety Grade	2 (DIN 31006-01)
Power Consumption	2,5VA
Response Time	< 30ms
Max. Inrush Current (A1 / A2) a.c. / d.c.	1,4A
Temperature Range: Operating	-25°...55°C
Reset Function	Manual or Auto (Link Selectable)
Supply Voltage:	24V a.c./d.c.
Safety Outputs: Device Type	Safety Relay, Force Operated Contacts
Contact Type/Quantity	2 x Normally Open
Contact Rating	5A @ 240Vac
Enclosure: Protection Rating	IP20
Terminal capacity	2 x 1,5mm ²
Material	Polycarbonate

Table 2